

## Foxboro™ DCS

### FBM237, 0 to 20 mA Output Module (Redundant)

#### PSS 41H-2S237

#### Product Specification

August 2019



# Legal Information

The Schneider Electric brand and any trademarks of Schneider Electric SE and its subsidiaries referred to in this guide are the property of Schneider Electric SE or its subsidiaries. All other brands may be trademarks of their respective owners.

This guide and its content are protected under applicable copyright laws and furnished for informational use only. No part of this guide may be reproduced or transmitted in any form or by any means (electronic, mechanical, photocopying, recording, or otherwise), for any purpose, without the prior written permission of Schneider Electric.

Schneider Electric does not grant any right or license for commercial use of the guide or its content, except for a non-exclusive and personal license to consult it on an "as is" basis. Schneider Electric products and equipment should be installed, operated, serviced, and maintained only by qualified personnel.

As standards, specifications, and designs change from time to time, information contained in this guide may be subject to change without notice.

To the extent permitted by applicable law, no responsibility or liability is assumed by Schneider Electric and its subsidiaries for any errors or omissions in the informational content of this material or consequences arising out of or resulting from the use of the information contained herein.

# Overview

The FBM237, 0 to 20 mA Output Interface Module contains eight channel isolated 0 to 20 mA dc analog output channels. The outputs are galvanically isolated from other channels and ground. The module can be used as a single unit, or as a redundant pair.

When used as a redundant pair, the modules combine to provide redundancy at the Fieldbus Module (FBM) level, with field output signals wired to one common termination assembly (TA) (see *Figure 1*). Each module in the pair independently holds the output(s) at its specified output value(s).

## Features

- Eight 4 to 20 mA dc analog output channels
- Each output channel is galvanically isolated
- Single or redundant modules
- Rugged design suitable for enclosure in Class G3 (harsh) environments
- TAs for locally or remotely connecting field wiring to the FBM237
- TA for use with Output Bypass Station to maintain outputs during maintenance operations
- 3-tier termination assembly for per channel internally and/or externally loop powered transmitters
- Electrically compatible with standard HART signals

## Redundant Analog Outputs

A redundant analog output function block, AOATR, is used for each redundant pair of outputs. The AOATR block handles output writes and initialization logic for the redundant channels. On each execution cycle identical output writes are sent to both modules, fully exercising the fieldbus and the logic circuitry of each module. When a failure is detected in one of the modules, its output is driven to 0 mA and the corresponding channel in the good module automatically continues supplying the proper current.

Each output channel drives an external load. Transmitter power from each module is diode OR'd together in the redundant adapter to help ensure redundant power. The microprocessor of each module executes the analog output application program, plus security routines that validate the health of the module.

Configurable options in the modules include Fail-Safe Action (Hold/Fallback), Analog Output Fail-Safe Fallback Data (on a per channel basis), Fieldbus Fail-Safe Enable, and Fieldbus Fail-Safe Delay Time. The Analog Output Fail-Safe Fallback Data option must be set for 0 mA output. This removes one of the pair of output channels from service for detectable problems such as a module not properly receiving output writes, or not passing security tests on FBM microprocessor writes to output registers. Setting of the Analog Output Fail-Safe Fallback Data option for 0 mA output also minimizes the possibility of a "fail high" result.

## Physical Design

FBM237 has a modular design, with a rugged extruded aluminum exterior for physical protection of the circuits. Enclosures specially designed for mounting the FBMs provide various levels of environmental protection, up to harsh environments (Class G3), per ISA Standard S71.04.

## High Reliability

The redundancy of the module pair, coupled with the high coverage of faults, provides a very high subsystem availability time.

Either module in the redundant pair may be replaced without upsetting field output signals to the good module. The module can be removed/replaced without removing field device termination cabling, power, or communications cabling.

## Visual Indicators

Light-emitting diodes (LEDs) incorporated into the front of the module provide visual status indications of FBM functions.

## Fieldbus Communication

A Fieldbus Communications Module or a Control Processor interfaces to the redundant 2 Mbps module Fieldbus used by the FBMs. The FBM237 accepts communication from either path (A or B) of the 2 Mbps Fieldbus. If one path is unsuccessful or is switched at the system level, the module continues communication over the active path.

## Modular Baseplate Mounting

The module mounts on the Standard Modular baseplate, which accommodates up to eight FBMs. The Modular baseplate is either DIN rail mounted or rack mounted, and includes signal connectors for redundant Fieldbus, redundant independent DC power, and termination cables. Redundant modules must be located in adjacent odd/even position pairs on the baseplate (positions 1 and 2, 3 and 4, 5 and 6, or 7 and 8). To achieve the redundant output, a redundant adapter module is placed on the two adjacent baseplate termination cable connectors to provide a single termination cable connection (see *Figure 1*). A single termination cable connects from the redundant adapter to the associated TA.

To system configurator applications and to other systems monitoring through SMON, Foxboro DCS System Manager, and SMDH, redundant FBM237 modules appear to be separate, nonredundant modules. The functional redundancy for these modules is provided by their associated control blocks.

## Termination Assemblies

Field I/O signals connect to the FBM subsystem via DIN rail mounted TAs. The TAs used with the FBM237 are described in *Termination Assemblies and Cables*, page 11.

**Figure 1 - Redundant I/O Configuration**

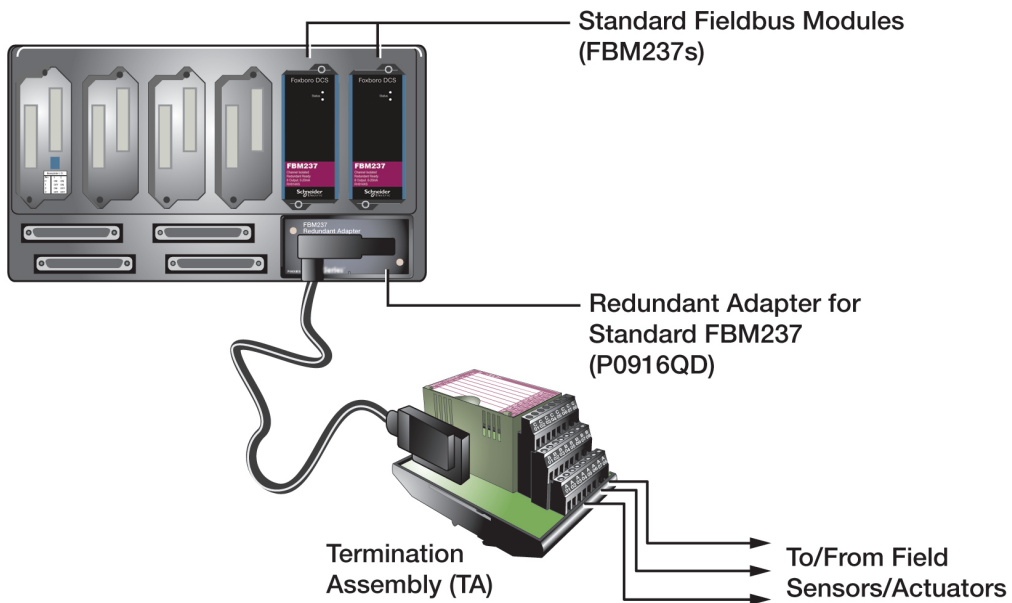

# Functional Specifications

Output Channels	Eight 20 mA dc analog output channels. Each channel is isolated and independent. Redundant pairs (output) are connected by a common field I/O connector, and therefore are not isolated from each other.
Accuracy — Analog (includes linearity)	±0.05% of Span (between 0.1 mA and 20 mA) Accuracy temperature coefficient: ±50 ppm/°C
Output Load	750 Ω maximum
Output Processing Delay	30 ms maximum
Output Range (each channel)	0 to 20.4 mA dc
Resolution	13 bits
Field Device Cabling Distance	Maximum distance of the field device from the FBM is a function of compliance voltage (18 V dc at 20.4 mA output), wire gauge, and voltage drop at the field device.
HART® Protocol Compatibility	The channels meet the impedance requirements for a HART high Impedance Device and can be used in a HART loop without interfering with the HART signals between the field device and a Hand-Held Communicator (HHC).
Loop Power Supply Protection	Each channel is channel-to-channel galvanically isolated, current limited and voltage regulated. All analog outputs are limited by their design to about 25 mA.
Isolation	<p>Each channel is galvanically isolated from all other channels and earth (ground). The module withstands, without damage, a potential of 600 V ac applied for one minute between any channel and ground, or between a given channel and any other channel.</p> <div style="background-color: black; color: white; text-align: center; padding: 5px;">  <b>DANGER</b> </div> <p><b>HAZARD OF ELECTRIC SHOCK, EXPLOSION, OR ARC FLASH</b></p> <p>This does not imply that these channels are intended for permanent connection to voltages of these levels. Exceeding the limits for input voltages, as stated elsewhere in this specification, violates electrical safety codes and may expose users to electric shock.</p> <p><b>Failure to follow these instructions will result in death or serious injury.</b></p>
Communication	Communication with its associated FCM or FCP via the module fieldbus.
Power Requirements	<ul style="list-style-type: none"> <li>• Input Voltage Range (Redundant): 24 V dc +5%, -10%</li> <li>• Consumption (Maximum): 7 W</li> <li>• Heat Dissipation (Maximum): 5 W</li> </ul>
Calibration Requirements	Calibration of the module and termination assembly is not required.
Regulatory Compliance: Electromagnetic Compatibility (EMC)	<ul style="list-style-type: none"> <li>• <i>European EMC Directive 2004/108/EC (Prior to April 20, 2016) and 2014/30/EU (Beginning April 20, 2016):</i> Meets: EN61326-1:2013 Class A Emissions and Industrial Immunity Levels</li> </ul>

Regulatory Compliance: Product Safety	<ul style="list-style-type: none"><li>• <i>Underwriters Laboratories (UL) for U.S. and Canada:</i> UL/UL-C listed as suitable for use in UL/UL-C listed Class I, Groups A-D; Division 2; temperature code T4 enclosure based systems when connected to specified Foxboro DCS processor modules. Communications circuits also meet the requirements for Class 2 as defined in Article 725 of the National Electrical Code (NFPA No.70) and Section 16 of the Canadian Electrical Code (CSA C22.1). For more information, see the <i>Standard and Compact 200 Series Subsystem User's Guide</i> (B0400FA).</li><li>• <i>European Low Voltage Directive 2006/95/EC (Prior to April 20, 2016) and 2014/35/EU (Beginning April 20, 2016) and Explosive Atmospheres (ATEX) directive 94/9/EC (Prior to April 20, 2016) and 2014/34/EU (Beginning April 20, 2016)</i> DEMKO certified as Ex nA IIC T4 for use in certified Zone 2 enclosure when connected to specified processor modules as described in the <i>Standard and Compact 200 Series Subsystem User's Guide</i> (B0400FA). <b>NOTE:</b> DEMKO Certification does not apply to Termination Assembly RH917QZ. See <i>Table 1</i>.</li></ul>
Marine Certification	ABS Type Approved and Bureau Veritas Marine certified for Environmental Category EC31.

## Environmental Specifications

	Operating	Storage
<b>Temperature</b>	<ul style="list-style-type: none"> <li>• Module: -20 to +70°C (-4 to +158°F)</li> <li>• Termination Assembly – PA: -20 to +70°C (-4 to +158°F)</li> </ul>	-40 to +70°C (-40 to +158°F)
<b>Relative Humidity</b>	5 to 95% (noncondensing)	5 to 95% (noncondensing)
<b>Altitude</b>	-300 to +3,000 m (-1,000 to +10,000 ft)	-300 to +12,000 m (-1,000 to +40,000 ft)
<b>Vibration</b>	7.5 m/s <sup>2</sup> (5 to 500 Hz)	
<b>Contamination</b>	Suitable for use in Class G3 (Harsh) environments as defined in ISA Standard S71.04, based on exposure testing according to EIA Standard 364-65, Class III.	



## Physical Specifications

Mounting	<ul style="list-style-type: none"> <li>• Module: The FBM237 mounts on a modular baseplate. The baseplate can be mounted on a DIN rail (horizontally or vertically), or horizontally on a 19-inch rack using a mounting kit. Redundant modules must be located in odd and even adjacent positions on the baseplate (positions 1 and 2, 3 and 4, 5 and 6, or 7 and 8) along with the appropriate redundancy adapter. See <i>Standard 200 Series Baseplates</i> (PSS 41H-2SBASPLT) for details. Alternatively, a non-redundant FBM237 mounts on a 100 Series conversion mounting structure. See <i>100 Series Conversion Mounting Structures</i> (PSS 41H-2W8) for details.</li> <li>• Termination Assembly: The TA mounts on a DIN rail and accommodates multiple DIN rail styles including 32 mm (1.26 in) and 35 mm 1.38 in)</li> </ul>
Weight	<ul style="list-style-type: none"> <li>• Module: 185 g (6.5 oz) approximate</li> <li>• Termination Assemblies: <ul style="list-style-type: none"> <li>◦ Compression: 181 g (0.40 lb, approximate)</li> <li>◦ Ring Lug: 249 g (0.55 lb, approximate)</li> </ul> </li> </ul>
Dimensions - Module	<ul style="list-style-type: none"> <li>• Height: 102 mm (4 in), 114 mm (4.5 in) including mounting lugs</li> <li>• Width: 45 mm (1.75 in)</li> <li>• Depth: 104 mm (4.11 in)</li> </ul>
Dimensions - Termination Assemblies	See <i>Dimensions - Nominal, page 14</i>
Part Numbers	<ul style="list-style-type: none"> <li>• FBM237 Module: RH914XS</li> <li>• Termination Assemblies: See <i>Table 1</i></li> <li>• Redundant Adapter: RH916QD</li> </ul>

Termination Cables	<ul style="list-style-type: none"> <li>• Cable Lengths: Up to 30 m (98 ft)</li> <li>• Cable Materials: Polyurethane or Low Smoke Zero Halogen (LSZH)</li> <li>• Termination Cable Type: Type 1 - See <i>Table 3</i></li> <li>• Cable Connection: 25-pin male D-subminiature</li> </ul>
Termination Assembly Construction	<ul style="list-style-type: none"> <li>• Material: Polyamide Material, compression</li> <li>• Terminal Blocks: Outputs - 3 tiers, 8 positions Output Bypass Jacks - 8 positions</li> </ul>
Field Termination Connections	<ul style="list-style-type: none"> <li>• Compression — Accepted Wiring Sizes: <ul style="list-style-type: none"> <li>◦ Solid/Stranded/AWG: 0.2 to 4 mm<sup>2</sup>/0.2 to 2.5 mm<sup>2</sup>/24 to 12 AWG</li> <li>◦ Stranded with Ferrules: 0.2 to 2.5 mm<sup>2</sup> with or without plastic collar</li> </ul> </li> </ul>

# Termination Assemblies and Cables

Field I/O signals connect to the FBM subsystem via DIN rail mounted termination assemblies, which are electrically passive. TAs for the FBM237 module are available in the following forms:

- Compression screw type using Polyamide (PA) material.

Each FBM237 Termination Assembly and its associated termination cable provide feedthrough connection between eight 2-wire analog output signals and the FBM237 Channel Isolated 0 to 20 mA Module.

The termination assembly can be used with a single FBM237 or with a redundant pair (two FBM237s). When used with a redundant module pair, the termination assembly is connected to the baseplate using a redundant adapter (RH916QD).

Termination Assembly (RH917QZ) includes built-in bypass jacks for each output channel. The bypass jacks accept a bypass plug from the I/A Series Output Bypass Station (Foxboro P/N P0900HJ) or other external 20 mA sources. This option should be considered for applications where maintaining output during maintenance operations is desired.

See *Table 1* for a list of TAs used with the FBM237 module.

A removable termination cable connects the DIN rail mounted TA to the FBM via a field connector on the Modular baseplate in which the FBM is installed. Termination cables are available in the following materials:

- Polyurethane
- Low Smoke Zero Halogen (LSZH).

Termination cables are available in a variety of lengths, up to 30 meters (98 feet), allowing the termination assembly to be mounted in either the enclosure or in an adjacent enclosure. See *Table 3, page 13* for a list of termination cables used with the TAs for the FBM237 module.

**Table 1 - 0 to 20 mA Analog Outputs - FBM237 Termination Assemblies**

FBM Type	Output		TA Part Number <sup>(a)</sup>	Termination Type <sup>(b)</sup>	TA Cable Type <sup>(c)</sup>	TA Cert. Type <sup>(d)</sup>
	Channel	Signal	PA			
FBM237	8	0 to 20 mA	RH916YE	C	1	1,2
FBM237	8	0 to 20 mA	RH917QZ with bypass jacks	C	1	4,5

(a) PA is polyamide rated from -20 to +70°C (-4 to +158°F).

(b) C = TA with compression terminals; RL = TA with ring lug terminals.

(c) See *Table 3, page 13* for cable part numbers and specifications.

(d) See *Table 2, page 12* for Termination Assembly certification definitions.

**Table 2 - Certifications for Termination Assemblies**

Type	Certification
Type 1	TAs are UL/UL-C listed as suitable for use in Class I; Groups A-D; Division 2 temperature code T4 hazardous locations. They are DEMKO certified Ex nA IIC T4 for use in Zone 2 potentially explosive atmospheres.
Type 2	TAs are UL/UL-C listed as associated apparatus for supplying non-incendive field circuits Class I; Groups A-D; Division 2 hazardous locations when connected to specified DIN rail mounted FBMs and field circuits meeting entity parameter constraints specified in <i>Standard and Compact 200 Series Subsystem User's Guide</i> (B0400FA). They are also DEMKO certified as associated apparatus for supplying field circuits for Group IIC, Zone 2 potentially explosive atmospheres. Field circuits are also Class 2 limited energy (60 V dc, 30 V ac, 100 VA or less) if customer-supplied equipment meets Class 2
Type 4	All field circuits are Class 2 limited energy (60 V dc, 30 V ac, 100 VA or less) if customer-supplied equipment meets Class 2 limits.
Type 5	The TA and its field circuitry are for use in only ordinary (non-hazardous) locations.

**Table 3 - Cable Types and Part Numbers**

Cable Length m (ft)	Type 1 P/PVC <sup>(a)</sup>	Type 1 LSZH <sup>(b)</sup>
0.5 (1.6)	RH916DA	RH928AA
1.0 (3.2)	RH916DB	RH928AB
2.0 (6.6)	RH931RM	RH928AC
3.0 (9.8)	RH916DC	RH928AD
5.0 (16.4)	RH916DD	RH928AE
10.0 (32.8)	RH916DE	RH928AF
15.0 (49.2)	RH916DF	RH928AG
20.0 (65.6)	RH916DG	RH928AH
25.0 (82.0)	RH916DH	RH928AJ
30.0 (98.4)	RH916DJ	RH928AK
<p>(a) P/PVC is polyurethane outer jacket and semi-rigid PVC primary conductor insulation. Temperature range: -20 to +80°C (-4 to +176°F).</p> <p>(b) Low smoke zero halogen or low smoke free of halogen (LSZH) is a material classification used for cable jacketing. LSZH is composed of thermoplastic or thermoset compounds that emit limited smoke and no halogen when exposed to high sources of heat. Temperature range: -40 to +105°C (-40 to +221°F).</p>		

## Use of Termination Assemblies in 100 Series Upgrade Subsystem

When an FBM237 is used to replace the 100 Series FBM37, it may use any of the appropriate termination assemblies listed above for the FBM37's field I/O wiring. Alternatively, the FBM237 can accept this field wiring through a Termination Assembly Adapter (TAA) instead of a termination assembly. This is discussed in *Termination Assembly Adapter Modules for 100 Series Upgrade* (PSS 41H-2W4).

# Dimensions - Nominal

Compression Termination Assembly

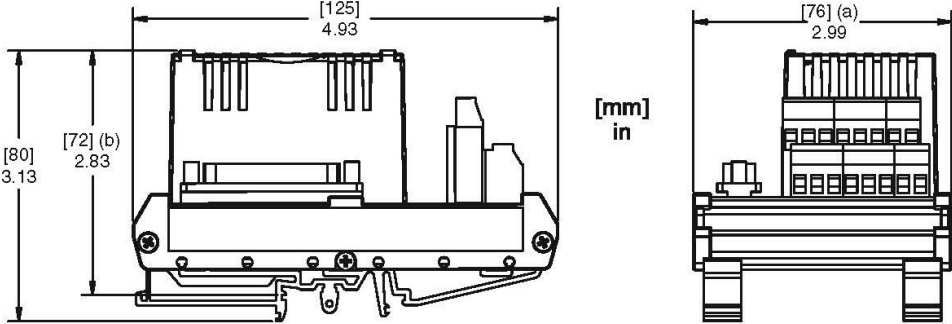

- (a) Overall width — for determining DIN rail loading.
- (b) Height above DIN rail (add to DIN rail height for total).

## Related Product Documents

<b>Document Number</b>	<b>Description</b>
PSS 41H-2SOV	<i>Standard 200 Series Subsystem Overview</i>
B0400FA	<i>Standard and Compact 200 Series Subsystem User's Guide</i>
PSS 41H-2W100	<i>100 Series Fieldbus Module Upgrade Subsystem Overview</i>
PSS 41H-2CERTS	<i>Standard and Compact 200 Series I/O - Agency Certifications</i>
PSS 41H-2W4	<i>Termination Assembly Adapter Modules for 100 Series Upgrade</i>
PSS 41H-2SBASPLT	<i>Standard 200 Series Baseplates</i>
PSS 41H-2W8	<i>100 Series Conversion Mounting Structures</i>
PSS 41S-3FCPICS	<i>Field Control Processor 280 (CP280) Integrated Control Software</i>

 **WARNING:** This product can expose you to chemicals including lead and lead compounds, which are known to the State of California to cause cancer and birth defects or other reproductive harm. For more information, go to [www.p65warnings.ca.gov/](http://www.p65warnings.ca.gov/).

Schneider Electric Systems USA, Inc.  
38 Neponset Avenue  
Foxboro, Massachusetts 02035-2037  
United States of America

Global Customer Support: <https://pasupport.schneider-electric.com>

As standards, specifications, and design change from time to time, please ask for confirmation of the information given in this publication.

© 2019 Schneider Electric. All rights reserved.

PSS 41H-2S237, Rev A